

Wireless enabling handle

Typical applications for interventions in dangerous machine area :

This product provides the operators intervening in hazardous areas :

- ➔ a means to control the equipment while having an individual protection system during interventions for adjustment and maintenance of moving machines, rotating machines, machining centers and automatic production lines («manual» mode).
- ➔ an individual protection system by holding a 3-position trigger («monitored-diagnostic» mode).



1- Description

The system comprises a wireless enabling handle, a charger and a safety receiver.

The wireless enabling handle has the following features :

- A 3-position trigger, ensuring a SIL3 safety level.
- 4 function buttons, configurable as « 4 control buttons » or as « function selection » buttons.
- A display, configurable in accordance with the applications (with customisation of identification of functions by pictograms).

The charger ensures the following functions :

- Contactless charging of the handle.
- Handle presence management.

The safety receiver has the following features :

- Depending on applications, one emergency stop input (ES), two-channel type or one safety light barrier input type 4 per EN 61 496 or one gate input.
- 1 radio input associated to the wireless enabling handle.
- 6 static outputs associated to the function buttons on the wireless enabling handle.
- 3 static outputs for indication of the operating state.
- Inputs monitoring presence of the handle on its charger support, to ensure automatic operation of the equipment.
- A selection of application programs (manual or automatic reset, machine area access management, ...).

Special attention has been given to use of the wireless enabling handle :

- Ergonomically designed to easily keep the trigger pressed continuously.
- Touch sensitive buttons.
- Functions identified by a configurable display.
- Adaptability to all radio configurations in the environment by the possibility for frequency changes.
- Function buttons mechanically protected to prevent any unintentional actions.
- Handle protected against dropping through the use of a specially designed envelope.

To further enhance safety when using this system, innovative technical solutions and options are also proposed :

- Operating range limitation.
- Infrared start-up validation (option) to ensure identification of the machine started up.

Easy to maintain :

- Customisation fully stored in a SIM card.
- Configuration software.
- Diagnostic aid display or indicators.

CONTENTS

Para.	Page
1- Description.....	p 1
2- Intervention on the equipment with the handle ...	p 2
3- Functions of the wireless enabling handle.....	p 3
4- Functions of the safety receiver	p 3
5- Technical characteristics	p 4
6- «Start-up by infrared validation» option	p 5
7- Configuring the safety receiver	p 5
8- Wiring diagrams.....	p 6
9- Product dimensions	p 7
10- Selection guide, references for ordering.....	p 8

● Compliant with European directives and standards :

- Hertzian equipment and telecommunication terminals (low voltage, EM compatibility, radiofrequency spectrum)
- Machinery 2006-42 with SIL3 safety level according to EN 61508-1-7 (2001) EN ISO 13849-1 (2008) for the performance level e (Category 4)
EC type certificate issued by TÜV NORD

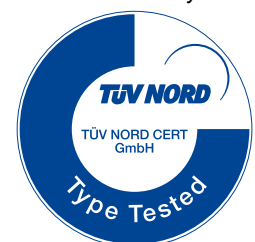

No 44 205 103632 52-001

2- Intervention on the equipment with the handle

This product is designed to provide an individual wireless control and protection system to the authorized personnel intervening for maintenance, adjustment or control of dangerous equipment.

There are two operating modes:

«Manual» mode

The enabling handle allows to check in full safety the functioning of the equipment after an adjustment or a maintenance intervention.

The transition from automatic mode to manual mode of the equipment will be ensured by withdrawing the handle from its charger.

The technician will be able to control the equipment in manual mode using the function buttons on the handle, associated to the handle trigger.

Once the intervention has been completed, the handle must be placed again on its charger to allow the machine to be restarted in automatic mode. (compliance with machinery Directive section **1.2.2 Service component**).

«Monitoring-diagnostic» mode

The handle provides an individual protection to the operator who needs to diagnose or check a running equipment.

Before entering the dangerous area, the technician picks up the validation handle from its charger **without deactivating the receiver safety relays**. If necessary, the machine speed can be lowered from the supervision station. In this case, the technician will only be able to access the machine area after he has received authorization from the supervision station (access gate unlocked).

By keeping the trigger on the handle pressed, the technician's safety is ensured by the personnel protection system provided by the enabling handle. **Any clenching of the hand on the trigger, or release of the trigger, will result in shutting down the machine.**

Once the intervention has been carried out, the technician must place the handle on its charger support to allow the machine to be restarted in automatic mode (compliance with machinery Directive section **1.2.2 Service component**).

In order to comply with the standard NF EN 12100-2, the intervention conditions on the equipment with this products are as follows :

- ➔ the risk evaluation shows that the intervening technician can avoid a hazardous situation should an immediate danger arise.
- ➔ The risk evaluation shows that the equipment shutdown time by release or clenching of the hand on the handle is sufficiently short to prevent any danger to the intervening technician.
- ➔ An emergency stop by release or clenching of the hand on the handle does not cause any additional hazardous situation.
- ➔ The technician can hold the handle in his hand without releasing the trigger.

When these 4 conditions are satisfied to operate in « monitoring-diagnostic mode », the equipment must be stopped and the handle must be used in equipment manual operating mode.

3- Functions of the wireless enabling handle

The handle is formed by a housing comprising 4 function buttons, a 3-position trigger and a display.

Clenching of the hand on the trigger or release of the trigger cause the safety contacts to open and immediate shutdown of the equipment.

The handle is easy to configure in accordance with the environment :

- ➔ The operating frequency can be modified.
- ➔ The radio power level can be modified to limit the range.

The change of configuration is lockable.

Using a configuration tool on PC (supplied with product), the handle can be configured in accordance with the application. It can be configured in «**4 control buttons**» mode (configuration on delivery) or in «**function selection**» mode.

- ➔ When configured for «**4 control buttons**», the technician is provided with 4 auxiliary control buttons (1).
- ➔ In «**function selection**» mode, the handle ensures different sequential controls (2).

Using the configuration tool, the handle screen display can be modified by integrating other pictograms from the library or by creating your own pictograms in BMP format.

A SIM memory card in the handle contains the product configuration. In the event of a handle malfunction, the SIM card can be transferred to another backup validation handle.

(up to 4 selections of 2 commands).



(1) = only with receivers **RSRB•400-0**

(2) = up to 4 selections of 2 commands with receivers **RSRB•400-0** or up to 10 selections of 2 commands with receiver **RSRB04C0-0**.

4- Functions of the safety receiver

The safety receiver has the following outputs : - **Opto-coupled 100 mA static outputs** : 6 function outputs.
- **Safety relays** : 2 safety relays with 3 NO guided contacts.

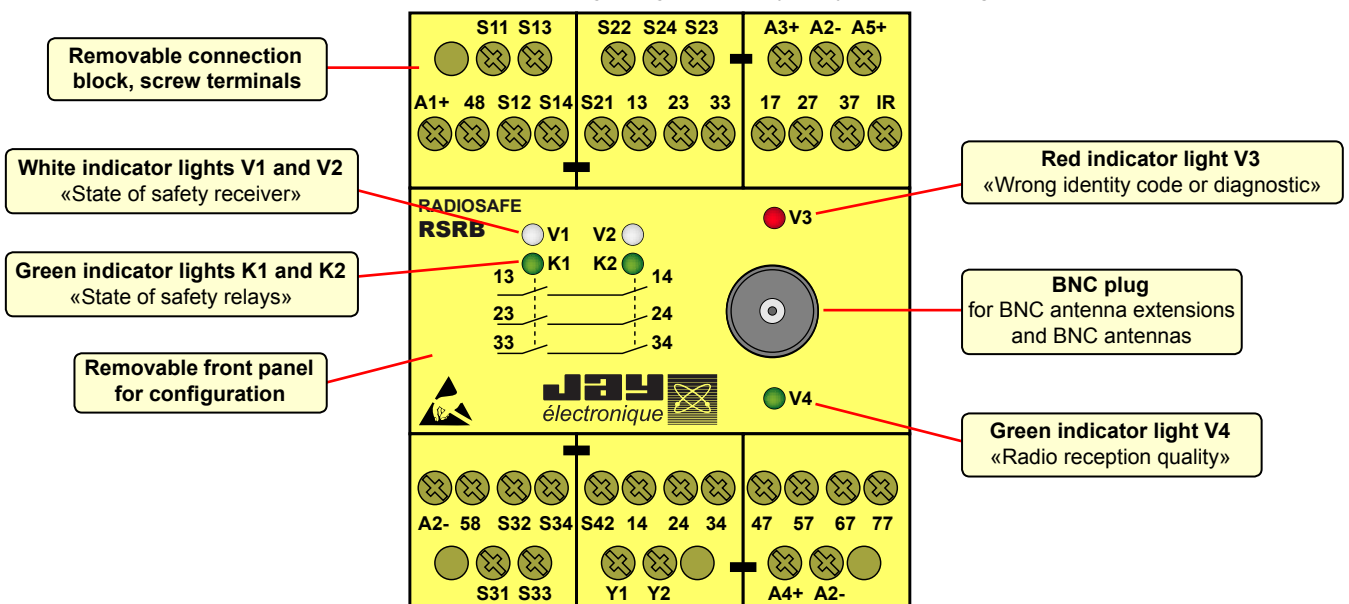

5- Technical characteristics

5.1- Wireless enabling handle RSEP

Mechanical characteristics and environmental withstand capacity
Housing material : Two-material plastic
Protection index : IP 54
Weight (with battery) : 340 g
Operating temperature range : -20 °C to + 50 °C
Storage temperature range : -20 °C to + 45 °C
Charging temperature range : 0 °C to + 35 °C
Electrical and radio characteristics
Power supply : Li-Ion battery
Endurance (at 25°C) :
Trigger activated : 8 hours
Trigger not activated : 40 hours
Complete charge duration : 6 hours
Radio transmit frequencies :
(Interval between adjacent channels : 0,025 MHz)
RSEP40 : 64 frequencies, from 433,100 MHz to 434,675 MHz
RSEP41 : 25 frequencies, from 434,075 MHz to 434,675 MHz
Transmit power : ≤10 mW
Average range in typical industrial environment (1) :
RSEP40 : 150 m
RSEP41 : 250 m
Functional characteristics
Display : Backlighted LCD
Function button type :
4 single-acting pushbuttons
Trigger : 3 positions
Range limitation : configurable
Indications :
Radio channel, battery level, diagnostic, displayable on enabling handle screen
Configuration of functions and display :
Configurable by PC software

(1) = Range will vary according to environment conditions of enabling handle and receiver reception antenna (frameworks, metal partitions, ...).

5.2- Charger support RSCP

Mechanical characteristics
Housing material : Plastic
Protection index : IP 40
Electrical characteristics
Power supply voltage : 24 V DC +/- 5%
Consumption when charging : 300 mA
Contact (handle detection) : 2 NO / 8 A
Handle detection : by infrared (contactless)
Type of charge : by induction (contactless)

5.3- Safety receiver RSRB

Mechanical characteristics and environmental withstand capacity
Housing material : Plastic
Protection index : IP 40
Weight : 500 g
Operating temperature range : 0 °C to + 50 °C
Storage temperature range : - 30 °C to + 70 °C
Connection : Screw terminals for wires 0.08 ² to 2.5 ²
Antenna : 1/4 wave, as accessory, plug-in on BNC connector
Electrical characteristics
Power supply voltage : 24 V DC +/- 15%
Max. consumption : 120 mA (solid state outputs not loaded)
Safety relay outputs :
Contacts : 3 NO with guided contacts
Triggering time (reaction) :
• Active stop time following clenching or release of trigger : 50 ms
• Passive stop time : 300 ms
Max. switching voltage : 250 V AC
Switching power :
• Per AC 15 : AC 3 A / 230 V for NO contacts NO EN60947-5-1
• Per DC 13 : DC 8 A / 24 V at 0.1 Hz EN60947-5-1
Electrical service life :
• Per AC15 at 2A, AC230V : 100 000 cycles EN60947-5-1
Solid state outputs :
Number and type of outputs : 6 PNP outputs
Output voltage : 24 V DC, 100 mA max.
Indication : 6 indicator lights

6- «Start-up by infrared validation» option

The start-up area of an equipment and the equipment's identification can be secured by an infrared validation on start-up.

Operating principle :

To start the equipment, the operator must be inside the IR transmit zone of the **UDF** module (referred to as the «Startup zone») and actuate the trigger on the handle.

- ➔ Once the validation has been performed, the «Handle/ Equipment to be controlled» pairing takes place with no possibility for error.
- ➔ The operator can then move around freely with no limitation.

This option is recommended when the reset mode is performed from the enabling handle trigger.

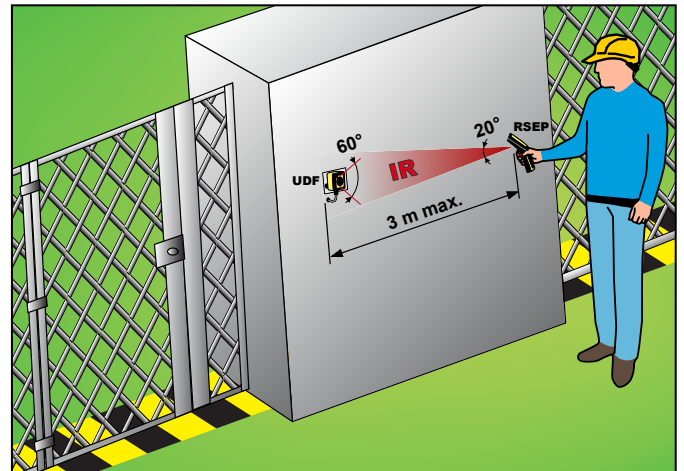

7- Configuring the safety receiver

The inputs and the restart mode of the safety receiver can be configured to meet the specific needs of the application. The configuration devices are accessed by removing the front panel from the unit :

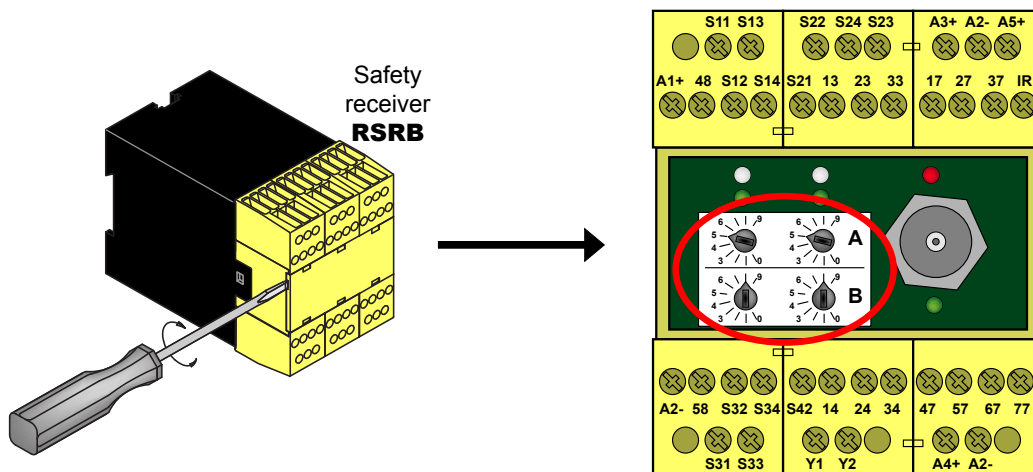

7.1- Choosing the receiver program

The receiver has 10 programs which are user-definable by the 2 «B» selectors.

« B » selector position	Reset mode, following a wired emergency shutdown or opening of a gate	Reset mode, following release or clenching of the handle trigger	Dangerous area access control	Remarks
0	Control console	Trigger	NO	
1	Control console	Control console	NO	
2	Automatic	Trigger	NO	
3	Automatic	Control console	NO	
8 *	Control console	Trigger	YES	The safety receiver controls access to the dangerous area using the enabling handle.
9 *	Control console	Control console	YES	The safety receiver controls access to the dangerous area using the enabling handle.

* = «function selection» mode for the wireless enabling handle is not available with programs 8 and 9.

7.2- Adjustment of handle pick up or zone access time delay

The machine area access time and the time during which the gate or safety light barrier is inhibited to allow intervention in a machine area are configurable using the 2 « A » selectors on the receiver.

	10 selectable times
Machine area access time	5 s. to 30 s.
Inhibit time (Muting)	5 s. to 10 min.

8- Wiring diagrams

8.1- Wiring diagram without receiver management of a machine area access

- In addition to the radio input associated to the wireless enabling handle, one emergency stop can be wired on the receiver.
- The receiver must be configured with application programs « 0 to 3 » (B selectors).
- Possibility of monitoring main contactor contacts C1 and C2 connected on safety outputs K1 and K2 (a1). This monitoring depends on the safety performance level required by the equipment.

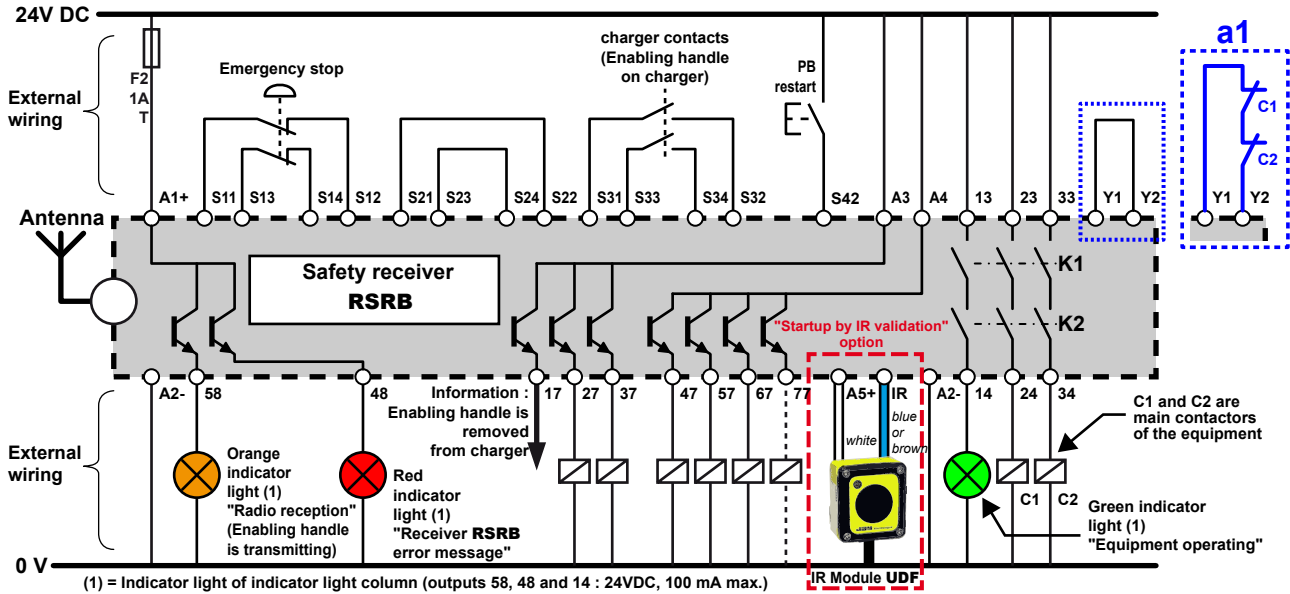

8.2- Wiring diagram with receiver management of a machine area access

- The receiver manages the access to the area (gate control input).
- In addition to the radio input associated to the wireless enabling handle, one emergency stop can be wired on the receiver.
- To manage an area access, the receiver must be configured with application programs « 8 or 9 » (B selectors).
- Possibility of monitoring main contactor contacts C1 and C2 connected on safety outputs K1 and K2 (a1). This monitoring depends on the safety performance level required by the equipment.
- Button B1 of the handle performs the access request to machine zone (active output 27 of receiver).

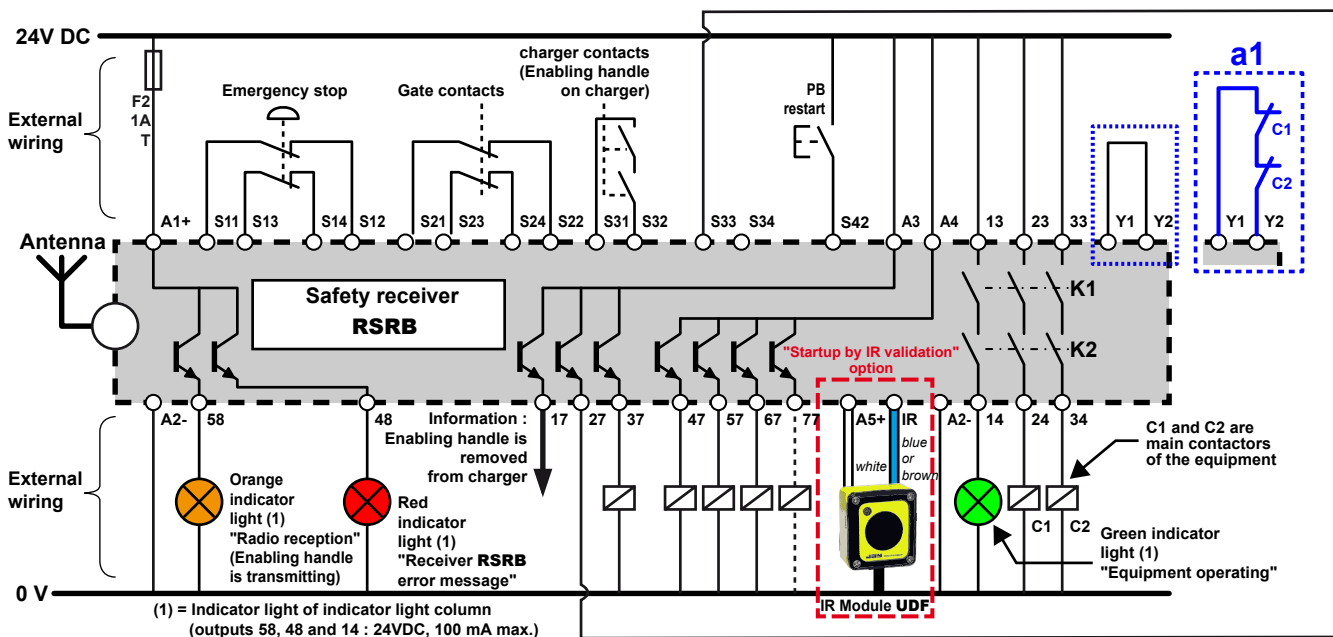

8.3- Output configuration

Standard receivers RSRB•400-0 :

«4 control buttons» mode (on delivery) :

Enabling handle buttons	Safety receiver RSRB outputs					
	27	37	47	57	67	77
B1	X				X	
B2		X			X	
B3			X		X	
B4				X	X	

«Function selection» mode :

Selected function (1)	Enabling handle buttons	Safety receiver RSRB outputs					
		27	37	47	57	67	77
F1	B1	X				X	
	B2		X			X	
F2	B1			X		X	
	B2				X	X	
F3	B1	X					X
	B2		X				X
F4	B1			X			X
	B2				X		X

(1) = Function selection is done by B3 and B4 buttons

Receiver with combined outputs RSRB04C0-0 :

Only with «function selection» mode :

Selected function (1)	Enabling handle buttons	Safety receiver RSRB outputs					
		27	37	47	57	67	77
F1	B1				X	X	
	B2				X		X
F2	B1			X		X	
	B2			X			X
F3	B1			X	X	X	
	B2			X	X		X
F4	B1		X			X	
	B2		X				X
F5	B1		X		X	X	
	B2		X		X		X
F6	B1		X	X		X	
	B2		X	X			X
F7	B1		X	X	X	X	
	B2		X	X	X		X
F8	B1	X				X	
	B2	X					X
F9	B1	X			X	X	
	B2	X			X		X
F10	B1	X		X		X	
	B2	X		X			X

(1) = Function selection is done by B3 and B4 buttons

9- Product dimensions (mm)

Wireless enabling handle RSEP

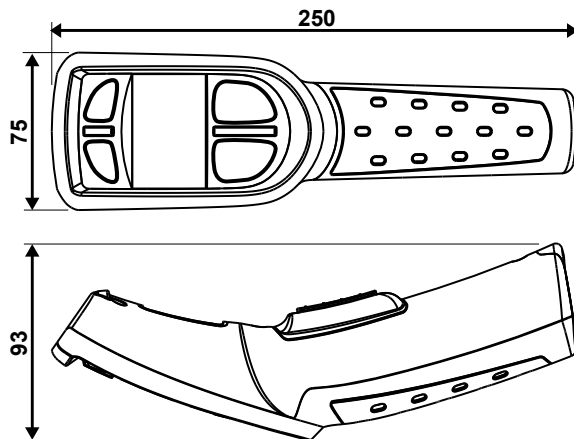

Charger support RSCP

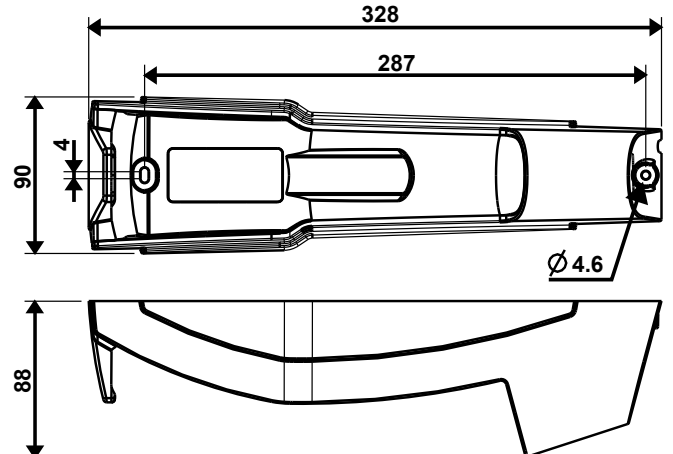

Safety receiver RSRB

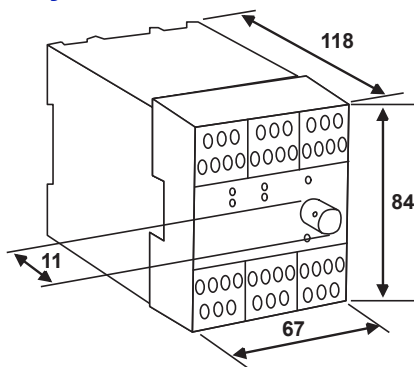

IR Module UDF

(for «Start-up by infrared validation» option)

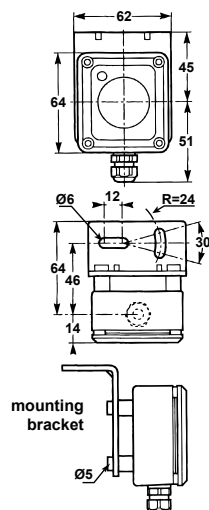

Voltage adapter RSCU

(for charger support RSCP)

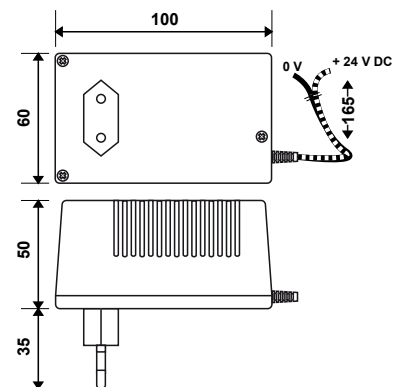

Plug-in BNC antennas











10- Selection guide, references for ordering

The RS Series «Wireless enabling handle» must be ordered as separate elements

Element	Picture	Reference	Description
Wireless enabling handle		RSEP40-0 handle with standard range RSEP41-0 handle with extended range	Delivered with : - CD (user manual and programming software) - USB cable
Safety receiver		RSRB0400-0 Standard model RSRB1400-0 Standard model, Programmed with «Start-up by infrared validation» option* RSRB04C0-0 Model with combined outputs	Delivered with : - SIM card - 90° BNC elbow VUB060 - BNC Antenna VUB084 - Ant. extension 0,5 m VUB170
Charger support		RSCP-0	24VDC power supply or with voltage adapter RSCU

* = The IR module ref.: **UDF1** must be ordered separately

Accessory	Picture	Reference	Description
SIM card		RSW21V	Blank delivered for maintenance
Voltage adapter (for charger support RSCP-0)		RSCU	230VAC - 24VDC
IR Module UDF (for «Start-up by infrared validation» option)		UDF1	Connection to receiver RSRB with 10 m cable
Extension cable kit for IR Module UDF		UDWR10	10 m extension
Carrying holster (for the handle)		RWP01	For carrying the handle when not in use. Fastens to belt, locking clip
Antennas		VUB084	1/4 wave BNC plug
		VUB086	1/2 wave BNC plug
Antenna elbow		VUB060	90° BNC elbow
Antenna extension cables		VUB170	Length 0,50 m BNC plug (without support)
		VUB105	Length 2 m BNC plug (with support)
		VUB125	Length 5 m BNC plug (with support)

The products presented in this document are subject to change. Product descriptions and characteristics are not contractually binding. Please go to our internet site www.jay-electronique.fr to download the most recent updates to our documentation.

E690 F - 0711

revision01