

Original instructions

Safety Contact Mats

ASK-series

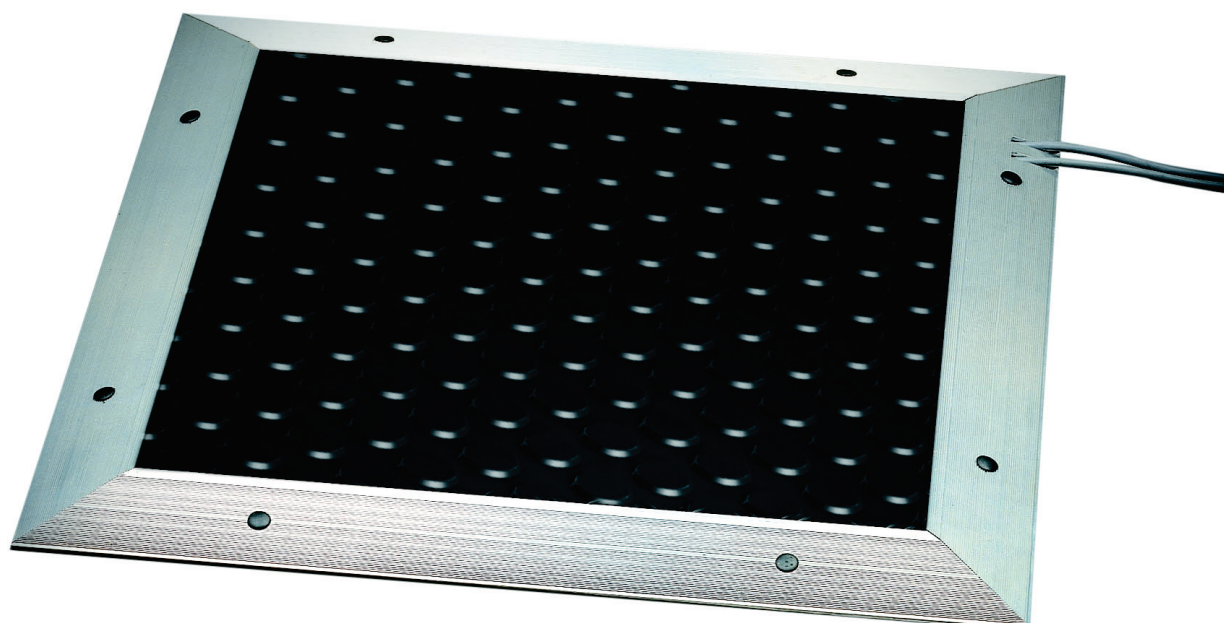
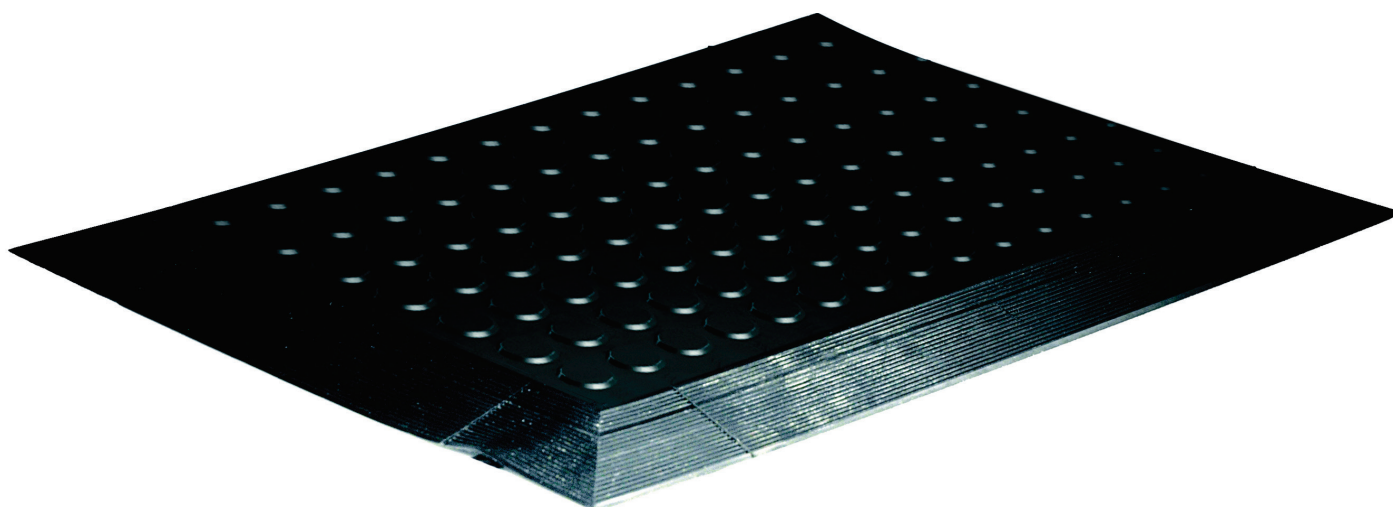

Read and understand this document

Please read and understand this document before using the products. Please consult your ABB/JOKAB SAFETY representative if you have any questions or comments.

WARRANTY

ABB/JOKAB SAFETY's exclusive warranty is that the products are free from defects in materials and workmanship for a period of one year (or other period if specified) from date of sale by ABB/JOKAB SAFETY.

ABB/JOKAB SAFETY MAKES NO WARRANTY OR REPRESENTATION, EXPRESSED OR IMPLIED, REGARDING NON-INFRINGEMENT, MERCHANTABILITY, OR FITNESS FOR PARTICULAR PURPOSE OF THE PRODUCTS, ANY BUYER OR USER ACKNOWLEDGES THAT THE BUYER OR USER ALONE HAS DETERMINED THAT THE PRODUCTS WILL SUITABLY MEET THE REQUIREMENTS OR THEIR INTENDED USE. ABB/JOKAB SAFETY DISCLAIMS ALL OTHER WARRANTIES, EXPRESSED OR IMPLIED.

LIMITATIONS OF LIABILITY

ABB/JOKAB SAFETY SHALL NOT BE RESPONSIBLE FOR SPECIAL, INDIRECT, OR CONSEQUENTIAL DAMAGES, LOSS OF PROFITS OR COMMERCIAL LOSS IN ANY WAY CONNECTED WITH THE PRODUCTS, WHETHER SUCH CLAIM IS BASED ON CONTRACT, WARRANTY, NEGLIGENCE, OR STRICT LIABILITY.

In no event shall responsibility of ABB/JOKAB SAFETY for any act exceed the individual price of the product on which liability asserted.

IN NO EVENT SHALL ABB/JOKAB SAFETY BE RESPONSIBLE FOR WARRANTY, REPAIR, OR OTHER CLAIMS REGARDING THE PRODUCTS UNLESS ABB/JOKAB SAFETY'S ANALYSIS CONFIRMS THAT THE PRODUCTS WERE PROPERLY HANDLED, STORED, INSTALLED, AND MAINTAINED AND NOT SUBJECT TO ABUSE, MISUSE, OR INAPPROPRIATE MODIFICATION OR REPAIR.

SUITABILITY FOR USE

ABB/JOKAB SAFETY shall not be responsible for conformity with any standards, codes, or regulations that apply to the combination of products in the customer's application or use of the product. At the customer's request, ABB/JOKAB SAFETY will provide applicable third party certification documents identifying ratings and limitations of use that apply to the products. This information by itself is not sufficient for a complete determination of the suitability of the products in combination with the end product, machine, system, or other application or use.

The following are some examples of applications for which particular attention must be given. This is not intended to be an exhaustive list of all possible uses of the products, nor is it intended to imply that the uses listed may be suitable for the products:

Outdoor use, uses involving potential chemical contamination or electrical interference, or conditions or uses not described in this document.

Nuclear energy control systems, combustion systems, railroad systems, aviation systems, medical equipment, amusement machines, vehicles, and installations subject to separate industry or government regulations.

Systems, machines, and equipment that could present a risk to life or property.

Please know and observe all prohibitions of use applicable to the products.

NEVER USE THE PRODUCTS FOR AN APPLICATION INVOLVING SERIOUS RISK TO LIFE OR PROPERTY WITHOUT ENSURING THAT THE SYSTEM AS A WHOLE HAS BEEN DESIGNED TO ADDRESS THE RISKS, AND THAT THE ABB/JOKAB SAFETY PRODUCT IS PROPERLY RATED AND INSTALLED FOR THE INTENDED USE WITHIN THE OVERALL EQUIPMENT OR SYSTEM.

PERFORMANCE DATA

While every effort has been taken to ensure the accuracy of the information contained in this manual ABB/JOKAB SAFETY cannot accept responsibility for errors or omissions and reserves the right to make changes and improvements without notice. Performance data given in this document is provided as a guide for the user in determining suitability and does not constitute a warranty. It may represent the result of ABB/JOKAB SAFETY'S test conditions, and the users must correlate it to actual application requirements. Actual performance is subject to the ABB/JOKAB SAFETY Warranty and Limitations of Liability.

Table of Contents

1	Introduction	4
	Scope	4
	Audience	4
	Prerequisites	4
	Special notes	4
2	Overview	5
	General description	5
	Safety regulations	5
3	Connections	6
4	Installation and maintenance	7
	Safety Mats – General	7
	Signal processing	7
	General Installation of Safety Mats	8
	Corner connectors and aluminum ramp rail	10
	Metallic checkered coverings	11
	Overmeasure	11
	Installation of mats with molded ramp rail	12
5	Electrical connections	14
	Installation precautions	16
	Maintenance	16
6	Model overview	17
7	Technical data	18
8	EC Declaration of conformity	19

1 Introduction

Scope

The purpose of these instructions is to describe the safety mats and to provide the necessary information required for installation and use.

Audience

This document is intended for authorized installation personnel.

Prerequisites

It is assumed that the reader of this document has knowledge of the following:

- Basic knowledge of ABB/Jokab Safety products.
- Knowledge of machine safety.

Special notes

Pay attention to the following special notes in the document:

 **Warning!** Danger of severe personal injury!
An instruction or procedure which, if not carried out correctly, may result in injury to the technician or other personnel.

Caution! Danger of damage to the equipment!
An instruction or procedure which, if not carried out correctly, may damage the equipment.

NB: Notes are used to provide important or explanatory information.

2 Overview

General description

The ASK Safety Mat is used as personal protection within the dangerous areas around presses, robots, production lines, machines etc. When connected to a suitable monitoring system stepping on the Safety Mat will immediately be detected causing dangerous machine movements to be stopped. This is made possible by the detection of electrical contacts closing within the sandwich construction of the Mat. As a load-bearing component the Mat is made with a bottom plate of either synthetic material or metal. The Safety Mat is provided with a slip-free surface. The safety mat and its connection cabling can be supervised by a suitable ABB/Jokab Safety safety relay, which provides up to PL d.

Safety regulations

Warning!

Carefully read through this entire manual before using the device.

The devices shall be installed by a trained electrician following the Safety regulations, standards and the Machine directive.

Failure to comply with instructions, operation that is not in accordance with the use prescribed in these instructions, improper installation or handling of the device can affect the safety of people and the plant.

For installation and prescribed use of the product, the special notes in the instructions must be carefully observed and the technical standards relevant to the application must be considered.

In case of failure to comply with the instructions or standards, especially when tampering with and/or modifying the product, any liability is excluded.

3 Connections

Safety Mats – Electrical connections

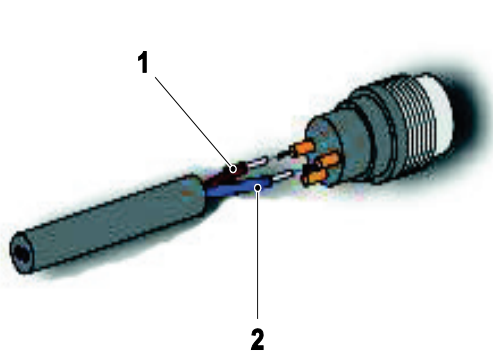

M8 Male pin configuration

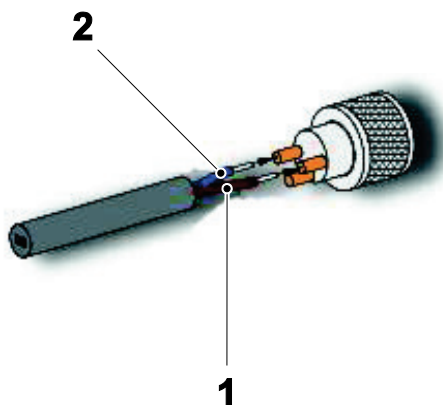

M8 female pin configuration

M8-connector:

- 1) Brown
- 2) Blue

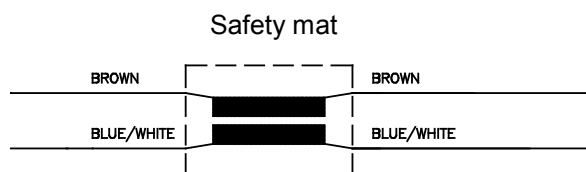

Accessories, Cables

Article number	Designation	Description
2TLA076900R3200	Safety Mat extension cable 2.5 m	2.5 meter cable with straight M8 female + male connector
2TLA076900R3300	Safety Mat extension cable 5 m	5 meter cable with straight M8 female + male connector

4 Installation and maintenance

Safety Mats – General

The basic mat construction consists of a ground plate of either, aluminium or stainless steel which provides a better protection against uneven ground etc. The Mat is made up of a sandwich construction, the pressure contact switch consisting of two conducting sheets separated from each other by a webbed isolating layer. The internal switching surface is cast into a durable polyurethane to protect against moisture, and this is then covered with a top layer of slip-free rubber mat or a thin aluminium plate. Attachment to the floor is by means of a ramped edge trim or special profiles made of aluminium. Two cable exits are provided. These cables consist of one M8 male plug and one M8 female plug in standard construction.

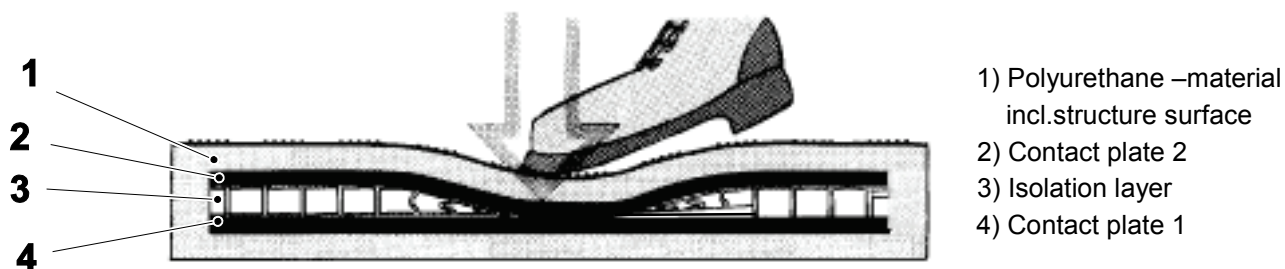

Signal processing

NB! Up to 10 contact mats wired in series may be connected to one evaluation control unit. The maximum total area can not exceed 10 m². The total cable length can not exceed 25 meter.

The Safety contact mat is fitted with 2 two-core connecting cables where both ends are connected to the safety evaluation unit. In each of the two cores there should be different signals (e.g. 24VDC vs. 0VDC). This connection makes a safety circuit where the safety evaluation unit provides the monitoring of the entire circuit including the cabling route and the mat.

If the two surfaces of the mat make contact when stepped on, a short circuit is detected between the different signals by the safety evaluation unit. This immediately causes the safe outputs to be turned off. The entire switching circuit is at the same time monitored for damage to cables or manipulation.

If several mats are to be connected together to one safety evaluation unit, they need to be connected in a series.

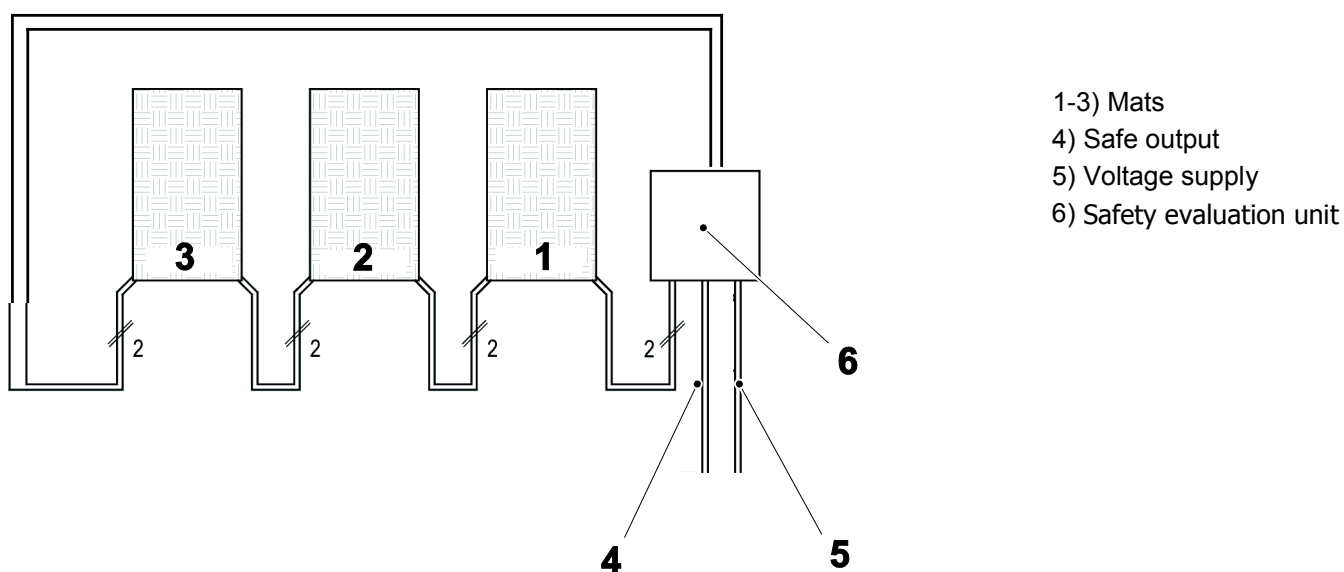

General Installation of Safety Mats

CAUTION!

The mats shall not be broken or bent. Safety mats must not be rolled/twisted or modified in any way. It is also essential that mats are not cut into any shape or shortened following delivery. The mounting surface must be absolutely even, clean and dry. Mats should not be glued on the bottom. Safety mats must not be rolled/twisted or modified in any way. It is also essential that mats are not cut into any shape or shortened following delivery.

Lay out and position the mat correctly with the base plate downwards. Safety contact mats may not be changed in any way. Cut outs or shortening is not possible. The mats shall be joined end to end when laying several mats together. Then connect the mats electrically and check the connection of each core(channel). During cable laying inside the ramp- and/or in the mounting rail pay attention that the cable is not pinched.

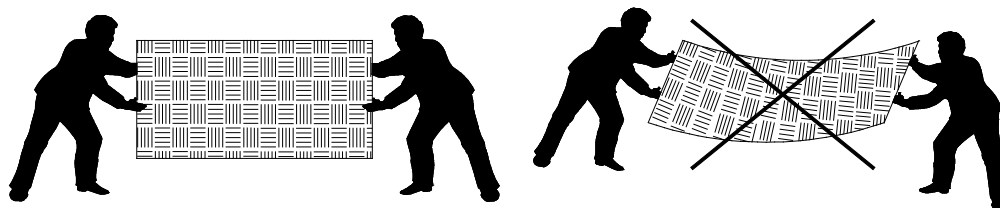

Correct!

Incorrect!

- 1) Place the mat in required position with the ground plate downwards. If more than one mat is to be installed be sure to place the mats edge to edge (without space). If the mats are delivered without the slip-free surface premounted, the selected surface should be placed in position over the mats and fixed by means of a suitable adhesive.

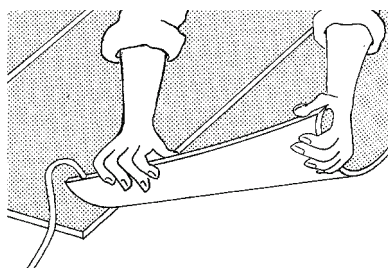

- 2) In the case of safety mats with cast-in rubber edge trim, the mat is secured to the floor by screws straight through the edge trim. In the case of safety mats with an aluminium edge trim, see below. Place the selected edge trim to the mat. Edge trims are sometimes mitred (at 45 degrees) to provide complete protection around the corners of the mat. Mark the cable routes on the edge trim and cut out slots to allow cable access into the profile cable channel. Connect the cables as shown under the chapter Electrical Connection. Mark the locations of the securing screws along the scribed line on the edge trim. It is recommended that fixing screws should be located at 60 cm spacing.

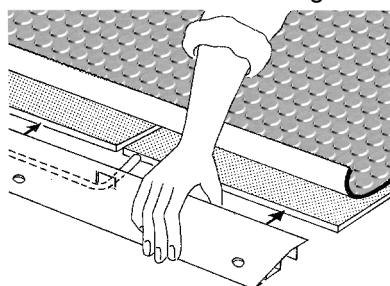

- 3) Secure the edge trim to the ground with 6 mm plugs and suitable screws. Plug the holes above the screws in the edge trim with the cover plugs provided.

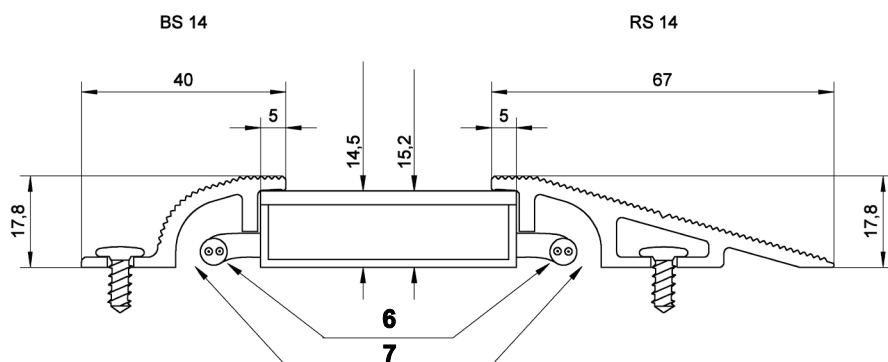
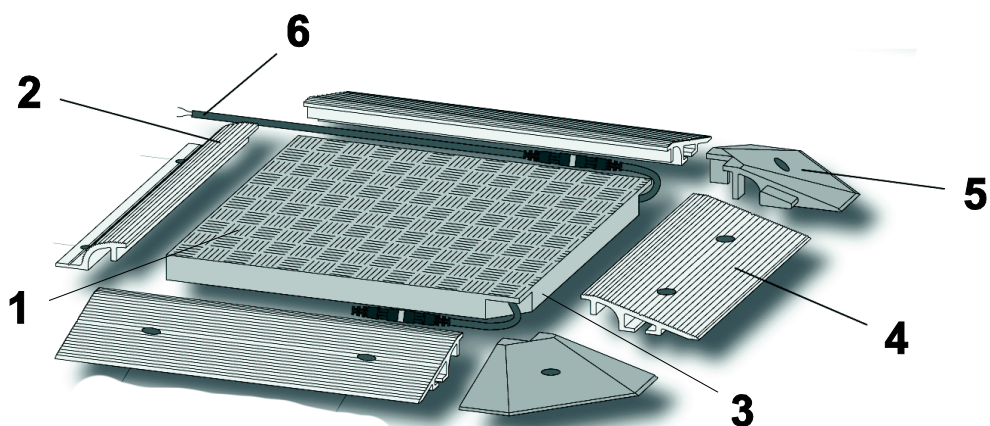
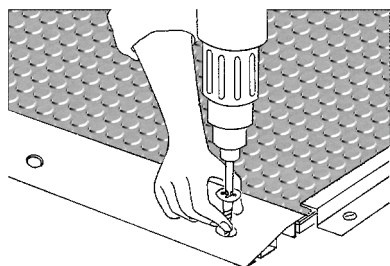

- 1) Surface protection
- 2) Mounting rail
- 3) Angle fixing profile
- 4) Ramp rail
- 5) Corner connection
- 6) Connection cable
- 7) Channel for connection cable

Corner connectors and aluminum ramp rail

When using corner connectors the ramp rail must be shortened around 20 mm for each corner connector. The corner connector nearest the cable is to be mounted from above over the cable in such a way that the cable is guided safely in the cable duct (A).

Afterwards drill and fasten it to the bottom with 6 mm dowel and suitable screw.

Push the ramp rails laterally to the mat and then on the fixation-pin of the corner connector (B).

Mark the fastening points along the marking groove on the rail and pre-drill 10 mm for the intended plugs. Fasten the rails on the bottom with 6 mm dowels and suitable screws. (approx. all 60 cm) and close the openings with the plugs (C). Push the corner connectors laterally to the mat and then the fixation –pin into the rail (D). Afterwards drill and fasten it to the bottom with 6 mm dowel and suitable screw.

At the machine side the conclusion takes place via the adjustment with the mounting rail BS 14. Fasten the rail to the bottom with 6 mm dowels and suitable screws (approx. all 60 cm). If possible bring out the cable laterally and attach it to the controller (E).

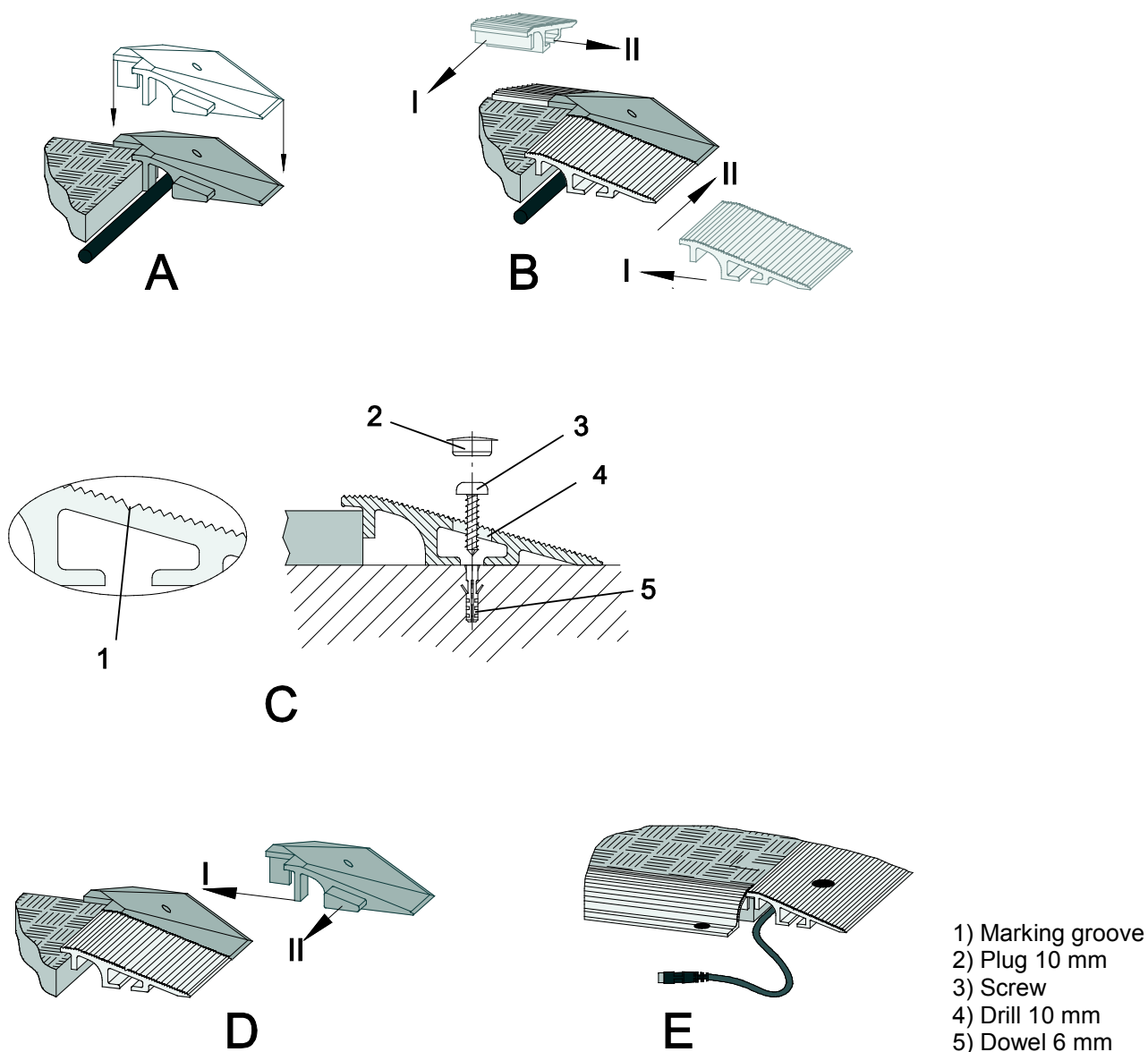

Metallic checkered coverings

It shall be noted for versions with metallic checkered coverings in aluminium (ARB) or stainless steel (TBV) that the coverings are connected together using a joining rail.

Overmeasure

The area to be safeguarded is made up by the dimension of the safety contact mat. The dimensions of 62 mm (for the ramp rail) and 35 mm (for the mounting-rail) must be added to this. The sum gives the total area required. The mounting-rail and the ramp rail are required for holding the mat in position on the floor. The maximum size that can be manufactured is 2350 mm x 1350 mm. Sizes larger than this can be realized by sequencing single mats.

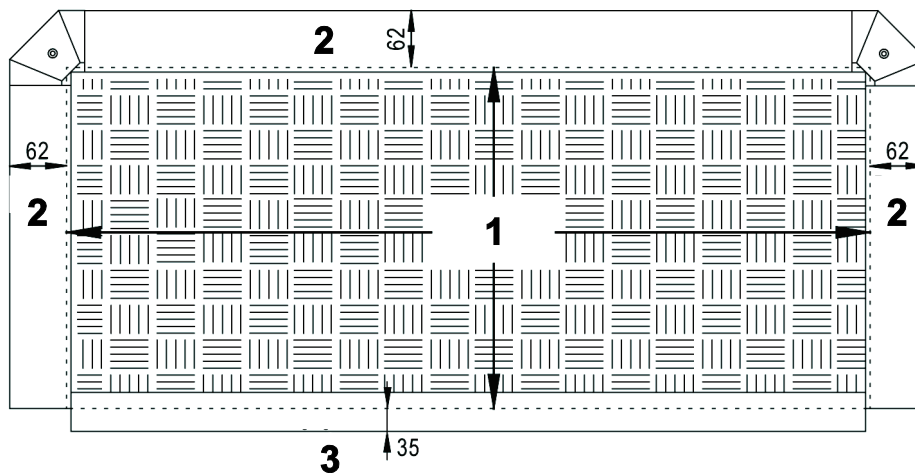

- 1) Mat dimension = Area to be safeguarded
- 2) Ramp rail
- 3) Mounting rail

Installation of mats with molded ramp rail

The safeguarded area (same as ordered size) on a Safety Mat with molded ramp rail is the dimensions of the mat without the ramp rails. Therefore 35mm have to be added for each ramp rail side to get the over-all dimension for the floor space. The ramp rail serves for fixation to the ground. 2350 mm x 1350 mm is the maximum producible size of mat. All dimensions larger than this have to be realized by using several mats.

- 1) Area for safeguard
- 2) Area for safeguard + 70 mm

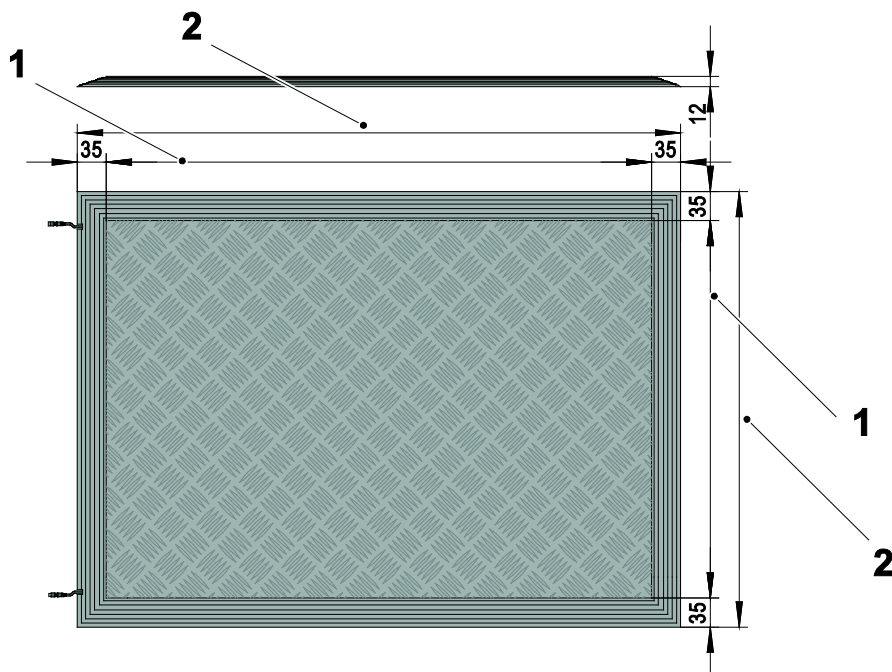

- 1) Cut out the cable output at appropriate side in that way that the coming out cables are not squeezed or sheared while placing the mat afterwards. Place and adjust the mat at the appropriate place. To provide against slipping use suitable screws and dowels on each side of the mat.

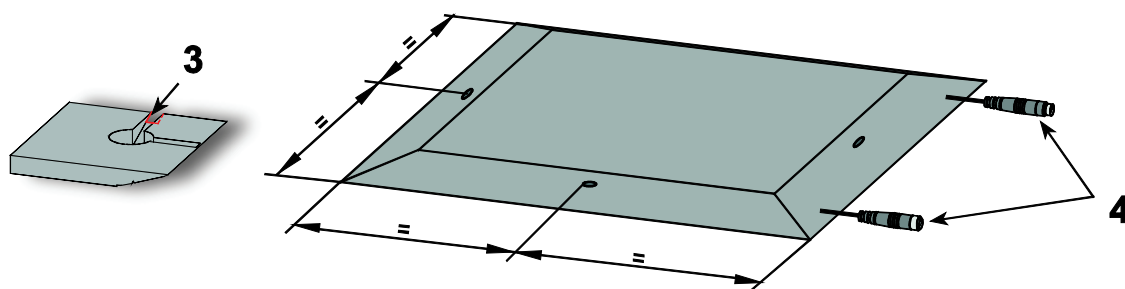

- 3) Cut out
- 4) Out coming cables

- 2) For placing several mats side by side the relevant ramp rails have to be cut off. To do this cut off the ramp rail with a knife in the given slit (B) (spray the knife and the cutting area with soapy water (A)). If needed the ramprail can of course be cut off also when mats not are joined together.

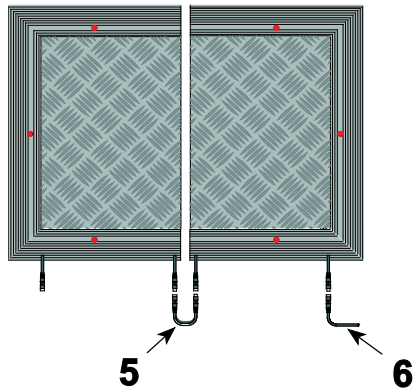

- 5) Connection cable with female and male plug M8
6) Supply cable with female plug M8

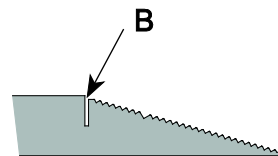
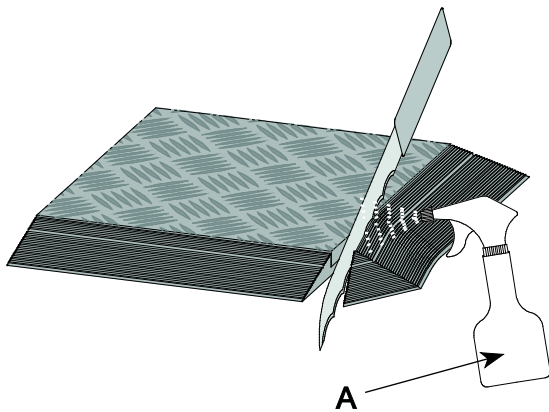

- 3) Then connect the mats electrically and check connection on the different cores (channels). If desired, aluminum ramp rail (RS14 or BS14) is possible to use also on Safety Mats with molded ramp rail, but then the molded ramp need to be cut of. See "General installation of Safety Mats".

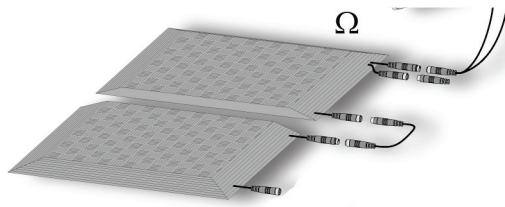

5 Electrical connections

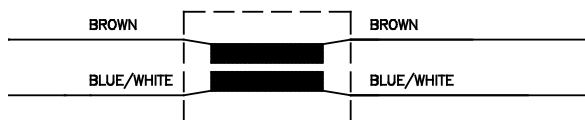

Safety contact mats must be connected to a suitable safety evaluation unit (e.g. ABB Jokab Safety safety relays RT6, RT7A/B, RT9, Vital with Tina 6A or Pluto safety-PLC).

The safety evaluation unit monitors the functionality of the contact protection and detects any disconnections or short-circuits in the lines. Several crush protection units can be connected in series while still retaining the same level of safety.

When pressure is applied, the active surface of the contact area in the contact protection is closed and the safety output on the monitoring unit trips. A stop signal will be sent to the machine's safety circuits preventing any dangerous movements.

NB! If alternative units are used rather than the recommended ABB/Jokab Safety relays, it is essential that the user checks their suitability before use. Failure to do so may result in incorrect operation and/or damage to the equipment and invalidate warranty.

Connection contact protection for safety relay RT6

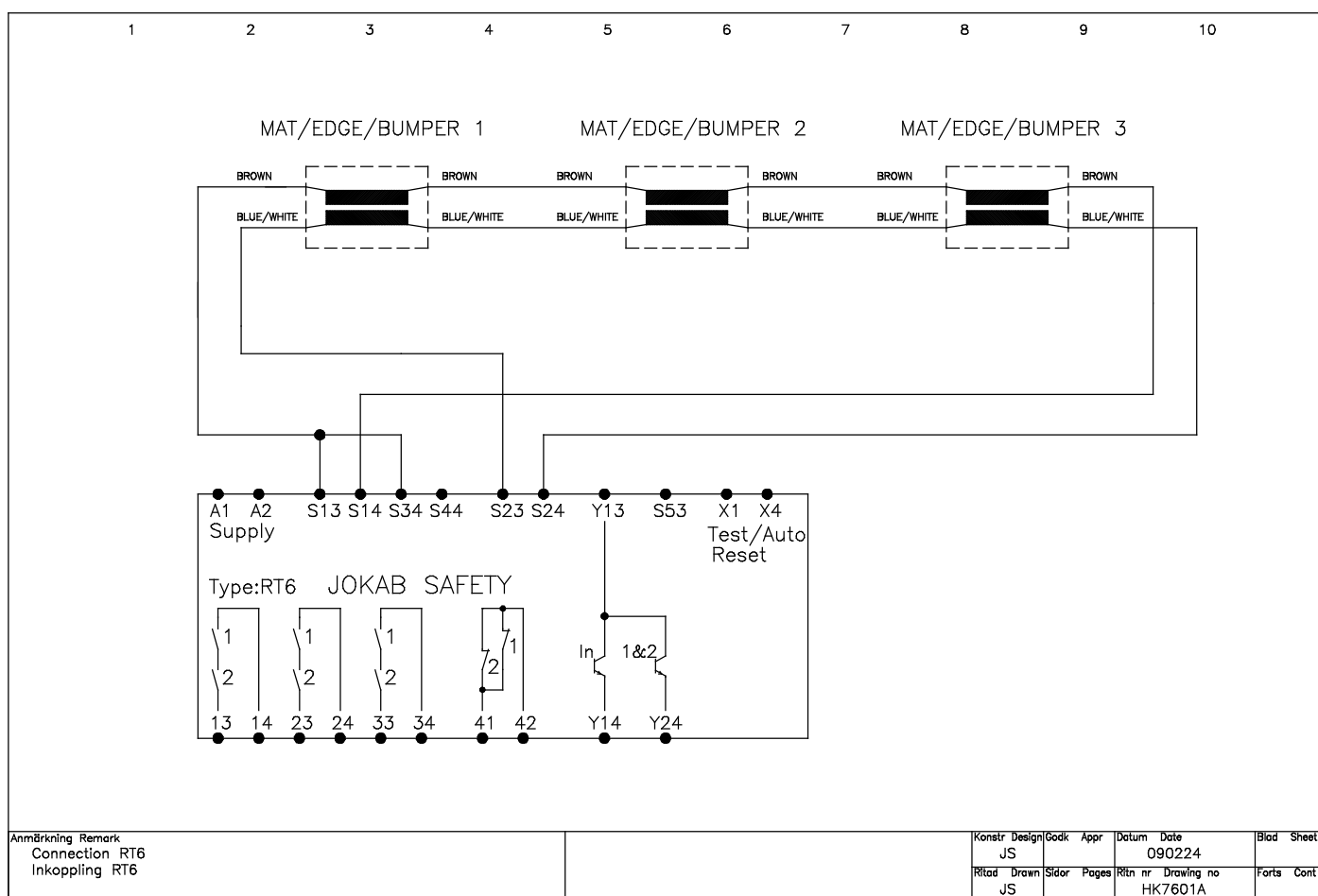

Anmärkning Remark
Connection RT6
Inkoppling RT6

Konstr	Design	Godk	Appr	Datum	Date	Blad	Sheet
JS				090224			
Ritad	Drawn	Sidor	Pages	Ritn nr	Drawing no	Forts	Cont
JS				HK7601A			

Connection contact protection for safety controller Vital 1

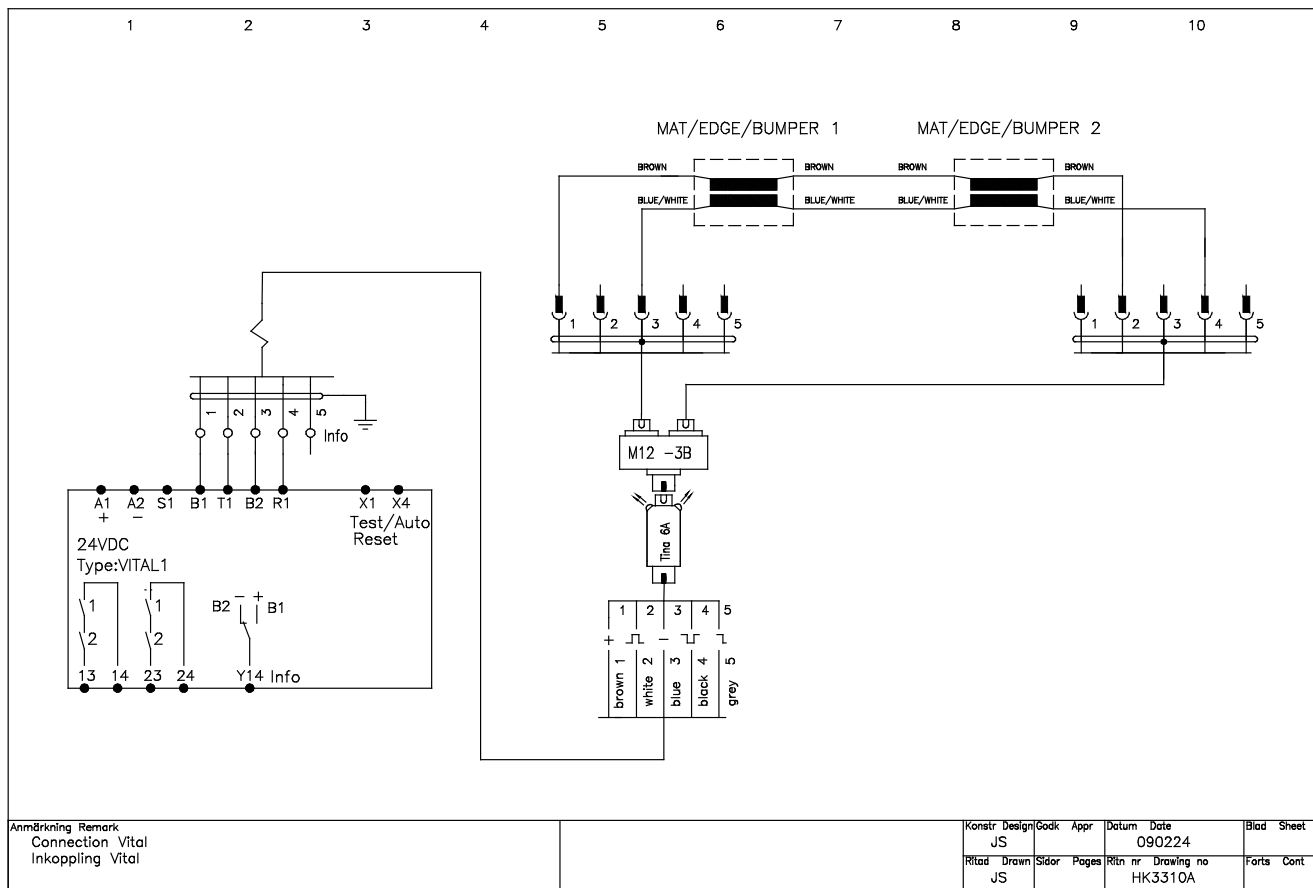

Connection contact protection for safety PLC Pluto

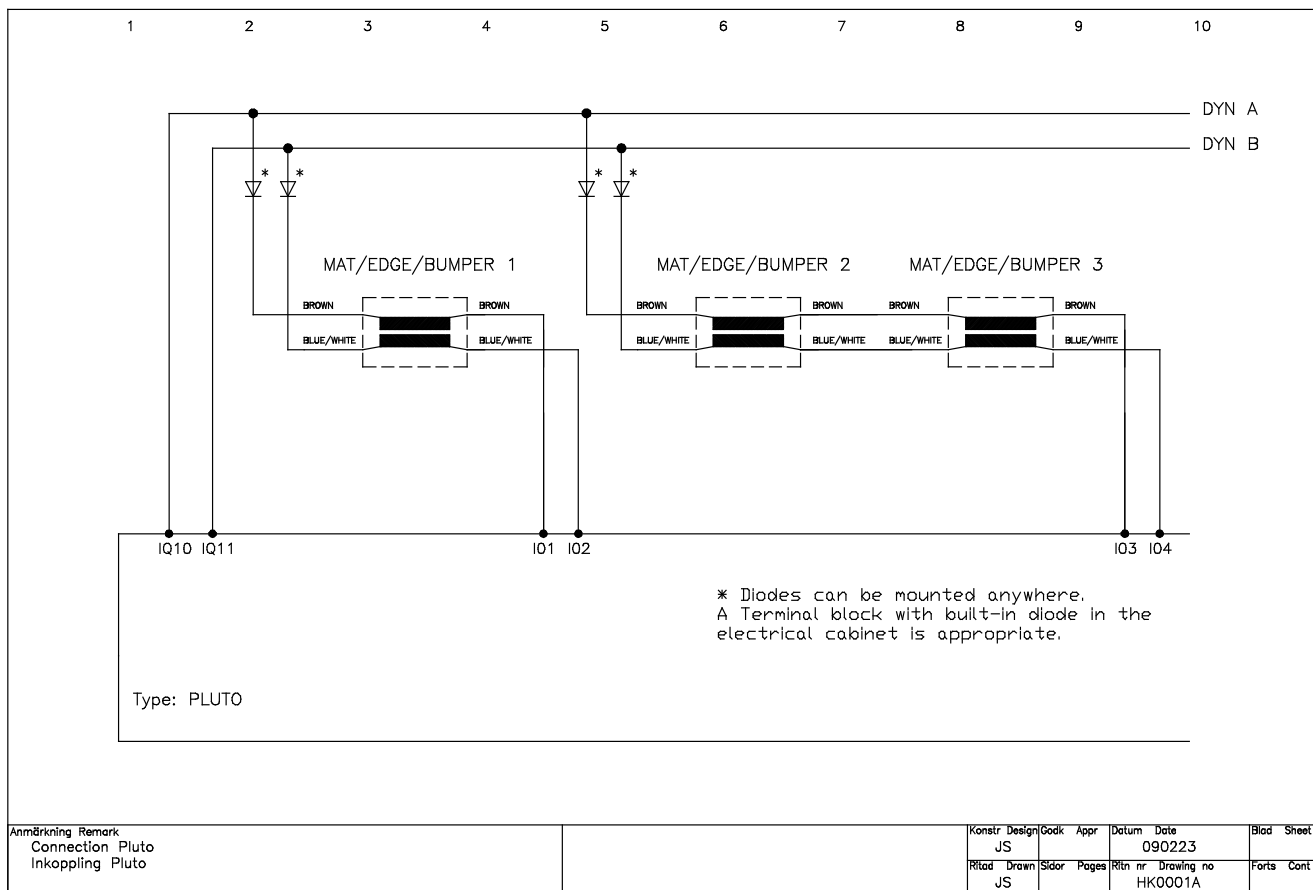

Installation precautions

 **Warning!** All the safety functions must be tested before starting up the system.

Maintenance

 **Warning!** The safety functions and the mechanics shall be tested regularly.

 **Warning!** In case of breakdown or damage to the product, contact the nearest ABB/Jokab Safety Service Office or reseller. Do not try to repair the product yourself since it may accidentally cause permanent damage to the product, impairing the safety of the device which in turn could lead to serious injury to personnel.

Caution! ABB/Jokab Safety will not accept responsibility for failure of the switch functions if the installation and maintenance requirements shown in this sheet are not implemented. These requirements form part of the product warranty.

6 Model overview

Article number	Description
ASK-1U4.4-NP Standard	
2TLA076310R0500	ASK-1U4.4-NP No ramp edge trim: 1000 x 750 mm , incl. 5+5 m cables
2TLA076310R0600	ASK-1U4.4-NP No ramp edge trim: 1000 x 1000 mm, incl. 5+5 m cables
2TLA076310R0700	ASK-1U4.4-NP No ramp edge trim: 1000 x 1500 mm, incl. 5+5 m cables
ASK-1U4.4-NP Custom made	
2TLA076301R0000	ASK-1U4.4-NP No ramp edge trim: Base price
2TLA076300R0000	ASK-1U4.4-NP No ramp edge trim: Base price special surface
2TLA076301R0500	ASK-1U4.4-NP No ramp edge trim: sq. m, incl. 5+5 m cables
ASK-1T4.4-NP Standard	
2TLA076310R1000	ASK-1T4.4-NP Cast in ramp edge trim: 1000 x 750 mm, incl. 5+5 m cables
2TLA076310R1100	ASK-1T4.4-NP Cast in ramp edge trim: 1000 x 1000 mm, incl. 5+5 m cables
2TLA076310R1200	ASK-1T4.4-NP Cast in ramp edge trim: 1000 x 1500 mm, incl. 5+5 m cables
ASK-1T4.4-NP Custom made	
2TLA076301R0200	ASK-1T4.4-NP Cast in ramp edge trim: Base price
2TLA076301R0600	ASK-1T4.4-NP Cast in ramp edge trim: sq. m, incl. 5+5 m cables

Article number	Description
Edge trim RS 14:	
2TLA076300R0500	Eliminates vertical edges and attaches the safety mat to the floor. Also provides protection and channel for connection cables.
Profile BS14:	
2TLA076300R0800	Best for use on the side nearest the machine. Permits a shorter distance from, for example, a wall.
Corner trim:	
2TLA076300R0900	Can be used between two RS 14 profiles as an alternative to mitre cutting of profiles.
2TLA076300R0800	Cutting cost for BS14 and RS14

Custom Made Mats

When ordering a custom made mat, two articles need to be ordered. A base price and a square meter price. When ordering, the size of the mat need to be specified (X meter x Y meters).

If the order contains a special surface (aluminum or steel) on a ASK-1U4.4-NP, the base price of a "special surface" should be used. When ordering, specifying of which surface is necessary.

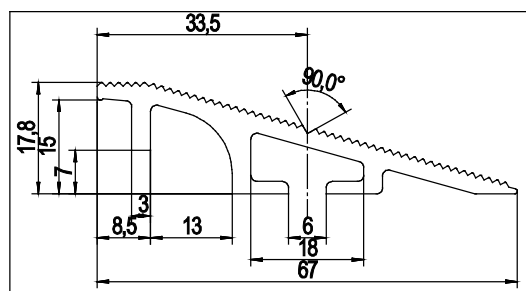

RS 14

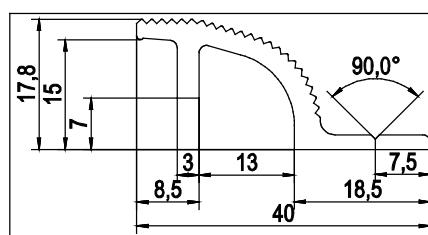

BS 14

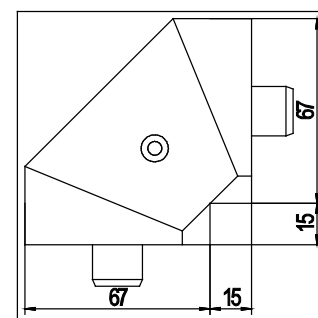

Corner connector

NB! Measurements are in mm

7 Technical data

Manufacturer	
Address	ABB AB / JOKAB SAFETY Varlabergsvägen 11 S-434 91 Kungsbacka Sweden
Max. area	Entire mat=2350 x1350 mm,10 m ² , (divided mat) Rec. relation max 3:1, Min 100 x 100 mm
Height	10 mm without slip-free surface max 14,5 mm with slip-free surface
Inactive area	Nominally 10 mm from mat edge
Switching force	150 N (Round body 80 mm)
Max. Pressure	2000 N over Ø 80 mm
Material	Black polyurethane, other colours on request
Protection class	IP 65
Electrical capacity	24 V 100 mA
Switching cycles	min. 1,5 Mio. (B10d: 2.000.000)*
Weight	approx. 15 kg/m ² (without covering)
Response time	max. 25 ms *
Ambient air temperature	0° C to + 60° C
Chemical resistance:	
Oil, grease	Good
10% acid	Resistant
10% alkaline (caustic) solutions	Resistant
Cable	2 x 5 m; 2 x 0,34 mm ² PU sheathed
Mechanical life	>1,5 x 10 ⁶ Load shifting

* Tested according to EN 1760-1

The Jokab Safety branded product with articlenumber beginning with 2TLJ is fully compatible with the ABB branded product with articlenumber beginning with 2TLA.

8 EC Declaration of conformity



EC Declaration of conformity

(according to 2006/42/EC, Annex 2A)

We ABB AB
JOKAB Safety
Varlabergsvägen 11
SE-434 39 Kungsbacka
Sweden

declare that the safety components of ABB AB make with type designations and safety functions as listed below, is in conformity with the Directives
2006/42/EC
2006/95/EC
2004/108/EC

Authorised to compile the technical file

ABB AB
JOKAB Safety
Varlabergsvägen 11
SE-434 39 Kungsbacka
Sweden

Product

Safety mats
ASK 14-1U.4-NP
ASK 14-1T.4-NP
ASK 14-1F.4 TBV
ASK 14-1F.4 ARB

With Safety Relays/Safety PLC

RT6, RT7A/B, RT9,
Vital 1 and Tina 6, Pluto

Used harmonised standards

With RT6, RT7A/B, RT9

EN 1760-1+A1:2009, EN ISO 12100:2010, EN ISO 13849-1:2008, EN 62061:2005,
EN 60204-1:2006+A1:2009, EN 60664-1:2007, EN 61000-6-2:2005,
EN 61000-6-3:2007, EN 60947-5-1:2003+A1:2009

With Vital 1 and Tina 6

EN 1760-1+A1:2009, EN ISO 12100-1:2010, EN ISO 13849-1:2008, EN 62061:2005,
EN 60204-1:2006+A1:2009, EN 61000-6-2:2005, EN 61000-6-4:2007,
EN 61496-1+A1:2008

With Pluto

EN 1760-1+A1:2009, EN ISO 13849-1:2006+AC:2009, EN 62061:2005,
EN 61496-1:2008+A1:2008, EN 574:1996+A1:2008, EN 692:2005+A1:2009,
EN 60204-1:2006+A1:2009, EN 50178:1997, EN 61000-6-2:2005,
EN 61000-6-4:2007, EN 61000-4-1...6

Other used standards

EN 61508:2010 (With RT6, RT7A/B, RT9, Vital 1 and Tina 6, Pluto)



Jesper Kristensson
PRU Manager
Kungsbacka 2012-05-25

www.abb.com
www.jokabsafety.com

Original